

TEXWRAP/TEKKRA REP:

DPG REP:

DATE RFQ SUBMITTED QUOTE DUE DATE SHRINK OR BUNDLE APPLICATION

CUSTOMER NAME		DISTRIBUTOR NAME	
CUSTOMER CONTACT		DISTRIBUTOR CONTACT	
STREET ADDRESS		STREET ADDRESS	
CITY, STATE, ZIP		CITY, STATE, ZIP	
PHONE NUMBER		PHONE NUMBER	
EMAIL ADDRESS		EMAIL ADDRESS	

DETAILS OF PRODUCT TO BE WRAPPED/BUNDLED:

--

PRODUCT ORIENTATION CHOICES:

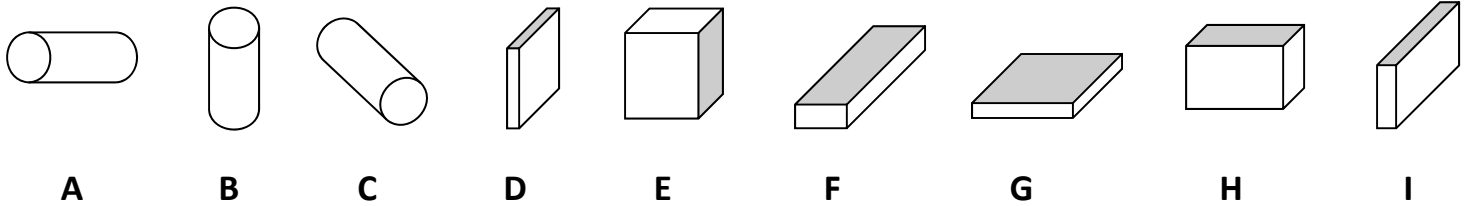

PRODUCT DIMENSIONS	PRODUCT #1	PRODUCT #2	PRODUCT #3	PRODUCT #4	PRODUCT #5	PRODUCT #6	PRODUCT #7	PRODUCT #8	PRODUCT #9
PRODUCT ORIENTATION (see above)									
INDIVIDUAL LENGTH/DIAMETER									
INDIVIDUAL WIDTH/DIAMETER									
INDIVIDUAL HEIGHT									
INDIVIDUAL WEIGHT									
INDIVIDUAL PRODUCTS PER MINUTE									
BUNDLE/MULTI-PACK LENGTH									
BUNDLE/MULTI-PACK WIDTH									
BUNDLE/MULTI-PACK HEIGHT									
BUNDLE/MULTI-PACKS WEIGHT									
BUNDLE/MULTI-PACKS PER MINUTE									
PACK PATTERN (see below example)									
IS THERE A BAR CODE TO READ?									
LIST ANY TRANSFER ISSUES:									

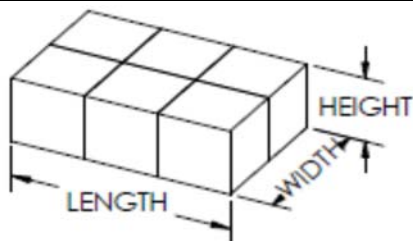

(#OF UNITS) L x W x H

LENGTH= 3
WIDTH = 2
HEIGHT = 1

OF UNITS= 6

PACK PATTERN IS: 3 X 2 X 1

DOES THE WRAPPED PACKAGE/BUNDLE REQUIRE FULLY ENCLOSED OR BULLS-EYE/BUNDLER ENCLOSURE?

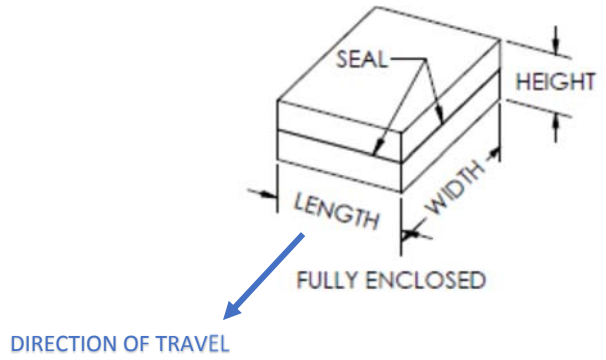
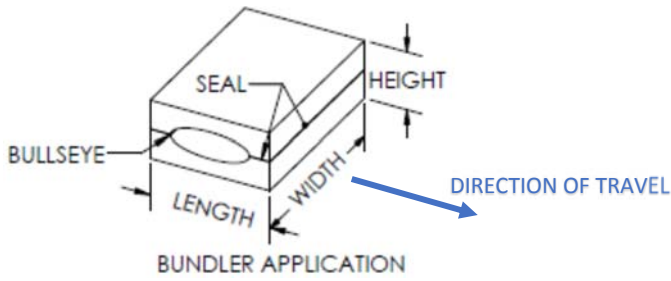

SELECT YOUR TYPE OF END SEAL:

VERTICAL SEAL
HORIZONTAL SEAL

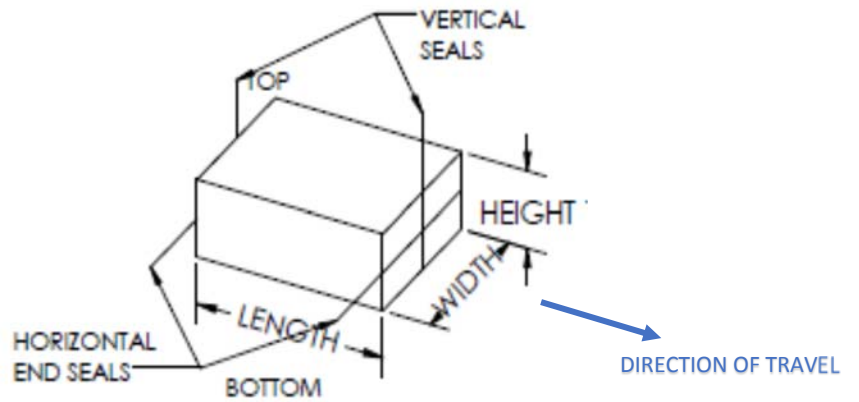

SELECT YOUR TYPE OF LONGITUDE SEAL:

L-BAR SEAL
SIDE SEAL
BOTTOM LAP
TOP LAP
BOTTOM TRIM
TOP TRIM
BAND TRIM
OTHER

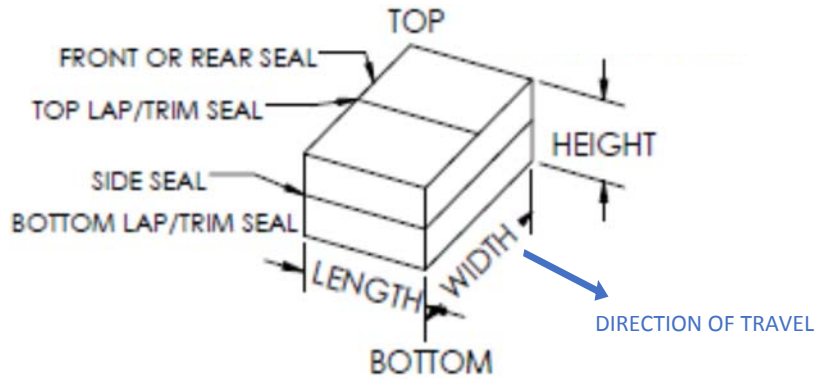

SELECT YOUR TYPE OF LAP SEAL:

STATIC
THERMAL
STATIC/THERMAL
TOP BAND
BOTTOM BAND
OTHER

HOW WILL THE PRODUCTS BE INTRODUCED TO THE WRAPPER?

HAND FED	WORKERS PLACING PRODUCT BY HAND ONTO WRAPPER
RANDOM	NO SPECIFIC SPACING
CHOKE-SPACED	PRODUCT IS FED END-TO-END WITH NO SEPERATION BETWEEN UNITS
SLUG	PRODUCTS ARRIVE IN GROUPS WITH RANDOM EMPTY GAPS
PITCH	A CONSISTANT SET SPACING BETWEEN EACH PRODUCT WITH NO VARIATION
OTHER	

IS THERE, OR WILL THERE BE A CUSTOMER SPECIFICATION PACKET? YES NO

DOES THE APPLICATION REQUIRE PRODUCT GUIDES? YES NO

ARE THERE SPECIAL HEIGHT REQUIREMENTS? IF SO, PLEASE LIST HEIGHT IN INCHES:

PLEASE DESCRIBE ANY OPTIONS OR DETAILS NOT COVERED BY THE SELECTIONS LISTED ABOVE:

EQUIPMENT SPECIFICATIONS:

MACHINE CONSTRUCTION:

STAINLESS STEEL

STEEL W/POWDERCOAT FINISH

IS THERE A SANITIZATION REQUIREMENT? YES NO WILL THE MACHINE BE SWABBED? YES NO

ELECTRICAL:

CLASS 1 / STANDARD

NEMA 12

NEMA 4X

WRAPPER VOLTAGE		PHASE		HERTZ	
TUNNEL VOLTAGE		PHASE		HERTZ	

IS UL OR OTHER CERTIFICATION REQUIRED? YES NO

PLANT AIR SUPPLY:

PSI		CFM	
-----	--	-----	--

PLANT TEMPERATURE RANGE (FARENHEIT):

	TO	
--	----	--

FACTORY ENVIRNMENT:

WET DRY SHIFTS/DAY:

ARE THERE SPACE CONSTRAINTS? YES NO IF YES, PLEASE LIST MEASUREMENTS:

PLEASE LIST ANY DETAILS NOT COVERED BY EQUIPMENT SPECIFICATIONS:

FILM INFORMATION:

FILM MANUFACTURER:	
FILM TYPE:	
GAUGE:	
FOLDED OR FLAT:	
PRINT REGISTRATION:	
RANDOM PRINT:	
PRE-PERFORATED:	

ORDER TIMING & COMPETITIVE INFORMATION:

BUDGETARY QUOTE

FORMAL QUOTE (PROJECT IS BUDGETED)

PURCHASE POTENTIAL (ENTER A % AMOUNT): < 60 DAYS 90-180 DAYS > 180 DAYS

IS THE PROJECT FUNDED? YES NO

CURRENT OPERATORS TO BE REPLACED BY MACHINE:

RETURN OF INVESTMENT TIMEFRAME: < 1 YEAR 1-2 YEARS 2+ YEARS

COMPETITIVE MANUFACTURER: **COMPETITIVE MODEL:**

CURRENT TEXWRAP / TEKKRA CUSTOMER? YES NO

PLEASE ATTACH ANY SPEC PACKAGES OR PICTURES OF PRODUCT(S) TO BE WRAPPED WHEN SUBMITTING THIS RFQ

SEND FINAL QUOTE TO:

- END USER**
- DISTRIBUTOR**
- BOTH**